

WIRE ROPE END FITTINGS

A full line of forged fittings and accessories for wire rope applications.



WIRE ROPE END FITTINGS

FORGED FOR CRITICAL APPLICATIONS

The proper performance of forged clips depends on proper manufacturing practices that include good forging techniques and accurate machining. Forged clips provide a greater rope bearing surface and more consistent strength than malleable cast iron clips. Fist Grip clips provide a saddle for both the "live" and the "dead" end. Fewer forged clips are required for each termination than with malleable cast iron clips. Forged clips reduce the possibility of hidden defects that are sometimes present in malleable cast iron clips. Malleable cast iron clips should only be used in non-critical applications. ASME, OSHA, and ASTM recommend only forged clips for critical applications.

Questions to ask your rigging provider

Is the clip forged?

Is an adequate cradle provided in the clip base for the wire rope?

Malleable cast iron clips are sometimes improperly used as replacements for forged clips.

Why choose Crosby

Crosby provides forged "Red" U-Bolt® Clips and forged Fist Grip clips which meet or exceed Federal Specification Number FF-C-450E and are considered the industry standard.

FULL LINE

The proper application of forged clips requires that the correct type, size, number, and installation instructions be used (See APPLICATION INFORMATION below for more information). Availability of a full range of sizes of forged U-bolt clips and forged Fist Grip clips are essential for design flexibility.

Questions to ask your rigging provider

Do they have both Fist Grip and U-bolt clips available?

Do they have a full range of forged wire rope clip sizes?

Malleable No competitor has the full line of forged U-Bolt clips and Fist Grip clips that Crosby has.

Why choose Crosby

Only Crosby provides forged "Red" U-Bolt® Clips from 1-1/8" to 3-1/2" and forged Fist Grip clips from 3/16" to 1-1/2".

* The 3-1/2" base is a steel casting.

IDENTIFICATION

The clip's size, manufacturer's logo, and a traceability code should be clearly embossed in the forging of the clip. These three elements are essential in developing total confidence in the product.

Questions to ask your rigging provider

Is the manufacturer's name and size of clip clearly marked?

Do they have a traceability system that is actively used in the manufacturing process?

Most do not have a traceability system.

Why choose Crosby

Crosby clearly embosses its logo, the size, and the Product Identification Code (PIC) into all Crosby "Red" U-bolt® Clip bases and Fist Grip clips. Crosby's traceability system is actively used throughout the manufacturing of forged clips. The material analysis for each heat of steel is verified within our own laboratory.

APPLICATION INFORMATION

Detailed application information will assist you in the proper installation of wire rope clips. This information is most effective when provided at the point of application, as well as in supporting brochures and engineering information. The manufacturer must provide this specific information. Generic information will not provide all the needed application instructions. A formal application and warning system that attracts the attention of the user, clearly informs the user of the factors involved in the task, and informs the user with the proper application procedures as needed.

Questions to ask your rigging provider

Does each clip have the application and warning information?

Most competitors do not have application and warnings information with each clip.

Why choose Crosby

Crosby provides detailed application and warning information for all forged clips. Each clip is individually bagged or tagged with the application and warning information. Testing and evaluation of special applications can be performed upon special request.

CROSBY VALUE ADDED

- **Full line:** Crosby provides both forged Red U-Bolt Clips and forged Fist Grip Clips.
- **Forged:** Crosby Red U-Bolt Clips have forged bases on all sizes, except 2-3/4" and 3-1/2" base is a steel casting. The entire clip is galvanized to resist corrosive and rusting action. Clip sizes 1/8" through 1-1/2" have U-Bolts with rolled threads which enhance the strength of the material and fatigue properties.
- **Forged:** Fist Grip Clips are forged, and the entire clip is galvanized. The double saddle design eliminates the possibility of incorrect installation. Designed as an integral part of the clip, the bolts are opposite one another (see G-429 example below). As result, the nuts can be installed in such a way as to enable the operator to swing the wrench in a full arc for ease of installation.
- **Application information:** Application and warning information is available for both Crosby Red U-Bolt Clips and Fist Grip Clips. The Crosby Warning System is designed to attract the attention of the user, clearly inform the user of the factors involved in the task, and provide the user with proper application procedures. Each Crosby Red U-Bolt Clip and Fist Grip Clip is either bagged or tagged with appropriate application and warning information, thus ensuring that the information is available at the point of application for each and every clip during installation.
- **Material analysis:** Crosby can provide certified material (mill) analysis for each production lot, traceable by the Product Identification Code (PIC). Crosby, through its own laboratory, verifies the analysis of each heat of steel.
- **Testing:** Crosby periodically audits the termination efficiencies of the Red U-Bolt Clips and Fist Grip Clips. Upon special request, Crosby will determine the efficiencies of clip assemblies when applied to special rope constructions and special applications.

7



G-450
Red U-Bolt® Clip



- Each base has a Product Identification Code (PIC) for material traceability, the name Crosby or "CG," and a size forged into it.
- Based on the catalog breaking strength of wire rope, Crosby wire rope clips have an efficiency rating of 80% for 1/8" through 7/8" sizes, and 90% for sizes 1" through 3-1/2".
- Entire clip is galvanized to resist corrosive and rusting action.
- Sizes 1/8" through 2-1/2" and 3" have forged bases.
- All clips are individually bagged or tagged with proper application instructions and warning information.
- Clip sizes up through 1-1/2" have rolled threads.
- Meets or exceeds all requirements of ASME B30.26 including identification, ductility, design factor, proof load and temperature requirements. Importantly, these wire rope clips meet other critical performance requirements, including fatigue life, impact properties, and material traceability not addressed by ASME B30.26.
- Look for the Red U-Bolt®, your assurance of genuine Crosby Clips.

APPLICATION AND WARNING INFORMATION
SECTION 17

G-450 Crosby Clips

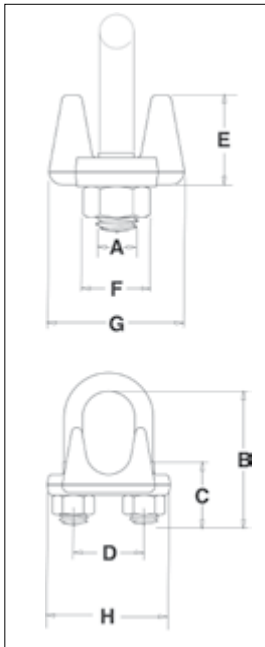

Rope Size		Stock No.	Std. Package Qty.	Weight Per 100 (lb)	Dimensions (in)							
(in)	(mm)				A	B	C	D	E	F	G	H
1/8	3-4*	1010015	100	6	.22	.72	.44	.47	.37	.38	.81	.99
3/16*	5*	1010033	100	10	.25	.97	.56	.59	.50	.44	.94	1.18
1/4	6-7	1010051	100	19	.31	1.03	.50	.75	.66	.56	1.19	1.43
5/16	8	1010079	100	28	.38	1.38	.75	.88	.73	.69	1.31	1.66
3/8	9-10	1010097	100	48	.44	1.50	.75	1.00	.91	.75	1.63	1.94
7/16 - 1/2	11-13	1010131	50	80	.50	1.88	1.00	1.19	1.13	.88	1.91	2.28
9/16 - 5/8	14-16	1010177	50	110	.56	2.25	1.25	1.31	1.34	.94	2.06	2.50
3/4	18-20	1010195	25	142	.62	2.75	1.44	1.50	1.39	1.06	2.25	2.84
7/8	22	1010211	25	212	.75	3.12	1.62	1.75	1.58	1.25	2.44	3.16
1	24-26	1010239	10	252	.75	3.50	1.81	1.88	1.77	1.25	2.63	3.47
1-1/8	28-30	1010257	10	283	.75	3.88	2.00	2.00	1.91	1.25	2.81	3.59
1-1/4	32-34	1010275	10	438	.88	4.44	2.22	2.34	2.17	1.44	3.13	4.13
1-3/8	36	1010293	10	442	.88	4.44	2.22	2.34	2.31	1.44	3.13	4.19
1-1/2	38	1010319	10	544	.88	4.94	2.38	2.59	2.44	1.44	3.41	4.44
1-5/8	41-42	1010337	Bulk	704	1.00	5.31	2.62	2.75	2.66	1.63	3.63	4.75
1-3/4	44-46	1010355	Bulk	934	1.13	5.75	2.75	3.06	2.92	1.81	3.81	5.24
2	48-52	1010373	Bulk	1300	1.25	6.44	3.00	3.38	3.03	2.00	4.44	5.88
2-1/4	56-58	1010391	Bulk	1600	1.25	7.13	3.19	3.88	3.19	2.00	4.56	6.38
2-1/2	62-65	1010417	Bulk	1900	1.25	7.69	3.44	4.13	3.69	2.00	4.69	6.63
** 2-3/4	** 68-72	1010435	Bulk	2300	1.25	8.31	3.56	4.38	4.88	2.00	5.00	6.88
3	75-78	1010453	Bulk	3100	1.50	9.19	3.88	4.75	4.44	2.38	5.31	7.61
** 3-1/2	** 85-90	1010426	Bulk	4000	1.50	10.75	4.50	5.50	6.00	2.38	6.19	8.38

*Electro-plated U-Bolt and Nuts. ** 2-3/4" and 3-1/2" base is made of cast steel.

G-429

Fist Grip® Clip
3/16" - 5/8"



3/16" - 5/8"

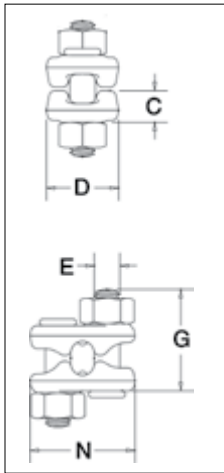

- Entire clip is galvanized to resist corrosive and rusting action.
- Based on the catalog breaking strength of wire rope, Crosby wire rope clips have an efficiency rating of 80% for 3/16" through 7/8" sizes, and 90% for sizes 1" through 1-1/2".
- Bolts are an integral part of the saddle. Nuts can be installed in such a way as to enable the operator to swing the wrench in a full arc for fast installation.
- All sizes have forged steel saddles.
- All Clips are individually bagged or tagged with proper application instructions and warning information.
- Meets or exceeds all requirements of ASME B30.26 including identification, ductility, design factor, proof load and temperature requirements. Importantly, these wire rope clips meet other critical performance requirements, including fatigue life, impact properties, and material traceability not addressed by ASME B30.26.
- Assembled with standard heavy hex nuts.

G-429 Fist Grip® Clips

Rope Size		Stock No.	Std. Package Qty.	Weight Per 100 (lb)	Dimensions (in)				
(in)*	(mm)				C	D	E	G	N
3/16 - 1/4	5-7	1010471	100	23	.40	.94	.38	1.41	1.44
5/16	8	1010499	100	28	.47	1.06	.38	1.50	1.54
3/8	10	1010514	50	40	.51	1.06	.44	1.84	1.78
7/16 - 1/2	11-13	1010532	50	62	.59	1.25	.50	2.21	2.15
9/16 - 5/8	14-16	1010550	50	103	.72	1.50	.63	2.72	2.57
3/4	18-20	1010578	25	175	.86	1.81	.75	2.94	2.67
7/8	22	1010596	25	225	.97	2.12	.75	3.31	2.86
1	24-26	1010612	10	300	1.13	2.25	.75	3.72	3.06
1-1/8	28-30	1010630	10	400	1.28	2.38	.88	4.22	3.44
1-1/4	32-34	1010658	10	400	1.34	2.50	.88	4.25	3.56
1-3/8 - 1-1/2	36-40	1010676	Bulk	700	1.56	3.00	1.00	5.56	4.12

* Sizes through 5/8" incorporate new style design.

G-429

Fist Grip® Clip
3/4" - 1-1/2"



3/4" - 1-1/2"

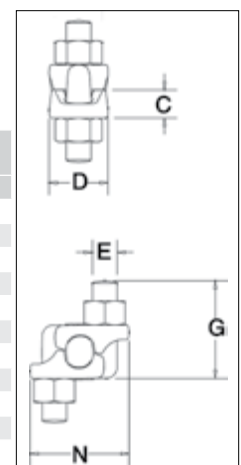

7

APPLICATION AND WARNING INFORMATION
SECTION 17

G-460 Soft Eye Bundle Clip

(For use without Thimble)

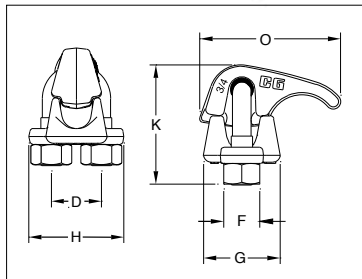

- Forged bases and bundle clip adapters.
- All bundle clips are individually bagged or tagged with proper application instructions and warning information.
- Bundle Clip Adapter for Soft Eye (G4460) and for Thimble Eye (G4461) kits available.
- Meets or exceeds all requirements of ASME B30.26 including manufacturing ID and size requirements. Importantly, these wire rope bundle clips meet material traceability not addressed by ASME B30.26.

G-461

Thimble
Eye Bundle Clip

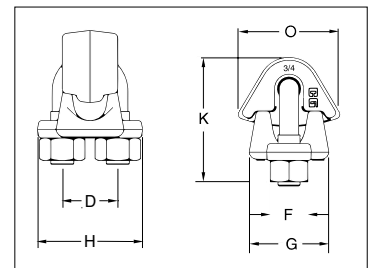

G-460 Soft Eye / G-461 Thimble Eye Bundle Clip

Rope Size		Bundle Clip Style	Stock No.	Dimensions (in)						Weight each (lb)
(in)	(mm)			D	F	G	H	K	O	
3/4	18-20	G460	1010509	1.50	1.06	2.25	2.84	3.50	4.13	2.5
3/4	18-20	G461	1010619	1.50	1.06	2.25	2.84	3.50	2.85	2.5

S-421T

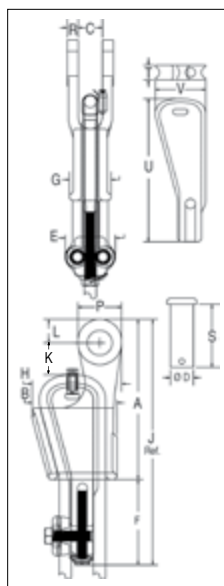

- Wedge socket terminations have an efficiency rating of 80% based on the catalog strength of XXIP wire rope.
- Meets or exceeds all requirements of ASME B30.26, including identification, ductility, design factor, proof load, and temperature requirements. Importantly, these sockets meet other critical performance requirements, including fatigue life, impact properties and material traceability, not addressed by ASME B30.26.
- Type Approval certification in accordance with ABS rules for conditions of classification, Part 1 2017 Steel Vessels and ABS guide for certification of lifting appliances 2017 available. Certificates available when requested at time of order and may include additional charges.
- Basket is cast steel and individually magnetic particle inspected.
- Pin diameter and jaw opening allows wedge and socket to be used in conjunction with closed swage and spelter sockets.
- Secures the tail or dead end of the wire rope to the wedge, thus eliminates loss or punch out of the wedge.
- Eliminates the need for an extra piece of rope and is easily installed.
- The Terminator wedge eliminates the potential breaking off of the tail due to fatigue.
- The tail, which is secured by the base of the clip and the wedge, is left undeformed.
- Incorporates Crosby's patented QUIC-CHECK® 'Go' and 'No-Go' feature cast into the wedge. The proper size rope is determined when the following criteria are met:
 - 1) The wire rope should pass through the 'Go' hole in the wedge.
 - 2) The wire rope should NOT pass through the 'No-Go' hole in the wedge.
- Utilizes standard Crosby Red U-Bolt® wire rope clip.
- The 3/8 through 1-1/8 standard S-421 wedge socket can be retrofitted with the new style Terminator wedge.
- Available with bolt, nut, and cotter pin: S-421TB.
- US patent 5,553,360, Canada patent 2,217,004, and foreign equivalents.
- Meets the performance requirements of EN 13411-6.
- Available with API-2C certification upon request.
- Wedge sockets meet the performance requirements of Federal specification RR-S-550F, Type C, except those provisions required of the contractor.
- The S-423T Super Terminator wedge is designed to be assembled only into the Crosby S-421T Terminator socket body. Important: The S-423TW for sizes 5/8" through 1-1/8" (14mm through 28mm) will fit respective size standard Crosby S-421T basket. The 1-1/4" (30-32mm) S-423TW will only fit the Crosby S-421T 1-1/4" basket marked with Terminator.

APPLICATION AND WARNING INFORMATION
SECTION 17

S-421T WEDGE SOCKETS (Assembly includes socket, wedge, pin and wire rope clip)

Wire Rope Dia.		Stock No.	Weight Each (lb)	Wedge Only	Weight Each (lb)	Standard Bolt, Nut & Cotter Assy	Weight Each (lb)
(in)	(mm)						
3/8	9-10	1035000	3.30	1035555	.50	2038971	.38
1/2	11-13	1035009	6.10	1035564	1.05	2038972	.69
5/8	14-16	1035018	10.5	1035573	1.79	2038974	1.15
3/4	18-19	1035027	16.4	1035582	2.60	2038976	1.91
7/8	20-22	1035036	24.8	1035591	4.00	2038978	3.23
1	24-26	1035045	35.5	1035600	5.37	2038980	5.40
1-1/8	28	1035054	48.8	1035609	7.30	2038982	7.50
1-1/4	30-32	1035063	71.5	1035618	10.60	2038984	10.34

Wire Rope Dia.		S-421T Stock No.	S-421TB Stock No.	Dimensions (in)														
(in)	(mm)			A	B	C +/- .09	D	G	H	J*	K*	L	P	R	S	T	U	V
3/8	9-10	1035000	1035203	5.69	2.72	.81	1.38	3.06	7.80	1.88	.88	1.56	.44	2.13	.44	1.25	1.38	
1/2	11-13	1035009	1035212	6.88	3.47	1.00	1.00	1.62	3.76	8.91	1.26	1.06	1.94	.50	2.56	.53	1.75	1.88
5/8	14-16	1035018	1035221	8.25	4.30	1.25	1.19	2.12	4.47	10.75	1.99	1.22	2.25	.56	3.25	.69	2.00	2.19
3/4	18-19	1035027	1035230	9.88	5.12	1.50	1.38	2.44	5.28	12.36	2.41	1.40	2.63	.66	3.63	.78	2.34	2.56
7/8	20-22	1035036	1035249	11.25	5.85	1.75	1.63	2.69	6.16	14.37	2.48	1.67	3.13	.75	4.31	.88	2.69	2.94
1	24-26	1035045	1035258	12.81	6.32	2.00	2.00	2.94	6.96	16.29	3.04	2.00	3.75	.88	4.70	1.03	2.88	3.28
1-1/8	28	1035054	1035267	14.38	6.92	2.25	2.25	3.31	7.62	18.34	2.56	2.25	4.25	1.00	5.44	1.10	3.25	3.56
1-1/4	30-32	1035063	1035276	16.34	8.73	2.62	2.50	3.56	9.39	20.48	2.94	2.34	4.50	1.06	6.13	1.19	4.62	4.94

* Nominal note: For intermediate wire rope sizes, use next larger size socket.

US-422T

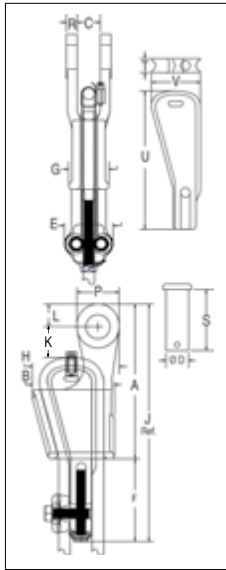

- Wedge socket terminations have an efficiency rating of 80% based on the catalog strength of XXIP wire rope.
- Meets or exceeds all requirements of ASME B30.26, including identification, ductility, design factor, proof load, and temperature requirements. Importantly, these sockets meet other critical performance requirements, including fatigue life, impact properties, and material traceability not addressed by ASME B30.26.
- Basket is cast steel and individually magnetic particle inspected.
- Wedges are color coded for easy identification.
 - Blue - largest wire line size for socket.
 - Black - mid size wire line for socket.
 - 7/16" on US4
 - 9/16" on US5
 - Orange - smallest wire line size for socket.
- By simply changing out the wedge, each socket can be utilized for various wire line sizes (ensure correct wedge is used for wire rope size).
- Cast into each wedge is the model number of the socket and the wire line size for which the wedge is to be used.
- Load pin is forged and headed on one end.
- US-422T wedge sockets contain a hammer pad (lip) to assist in proper securement of termination.
- Incorporates Crosby's patented QUIC-CHECK® 'Go' and 'No-Go' feature cast into the wedge. The proper size rope is determined when the following criteria are met:
 - 1) The wire rope should pass through the 'Go' hole in the wedge.
 - 2) The wire rope should NOT pass through the 'No-Go' hole in the wedge.
- Available with API-2C certification upon request.
- UWO-422T Wedges are to be used only with the US-422T Wedge Socket Assemblies.

7



APPLICATION AND WARNING INFORMATION
SECTION 17

US-422T Utility Wedge Sockets

Model No.	Wire Rope Size		Stock No.	Weight Each (lb)	Wedge Only Stock No.	Wedge Only Weight Each (lb)	Dimensions (in)														
	(in)	(mm)					A	B	C +/- .09	D	G	H	J	K	L	P	R	S	T	U	V
US4T	3/8	10	1044300	4.6	1047310	0.7	6.81	3.55	1.00	1.00	1.63	2.81	8.43	1.38	1.06	1.94	.50	2.53	.44	1.91	2.14
US4T	7/16	11	1044309	4.6	1047301	1.0	6.81	3.55	1.00	1.00	1.63	2.81	8.73	1.08	1.06	1.94	.50	2.53	.53	1.76	1.88
US4T	1/2	13	1044318	4.6	1047329	1.0	6.81	3.55	1.00	1.00	1.63	2.81	8.73	1.02	1.06	1.94	.50	2.53	.53	1.76	1.88
US5T	1/2	13	1044327	8.5	1047338	2.0	9.19	4.23	1.41	1.25	2.13	3.31	11.19	1.84	1.50	3.00	.63	3.25	.75	1.92	2.16
US5T	9/16	14	1044336	8.5	1047347	1.8	9.19	4.23	1.41	1.25	2.13	3.31	11.47	2.40	1.50	3.00	.63	3.25	.69	2.00	2.18
US5T	5/8	16	1044345	8.5	1047356	1.8	9.19	4.23	1.41	1.25	2.13	3.31	11.47	2.34	1.50	3.00	.63	3.25	.69	2.00	2.18
US6T	5/8	16	1044354	9.4	1047365	3.0	9.45	4.70	1.50	1.25	2.24	3.63	11.91	2.48	1.50	3.00	.56	3.25	.88	2.38	2.75
US6T	3/4	19	1044363	9.4	1047374	2.5	9.45	4.70	1.50	1.25	2.24	3.63	11.81	2.03	1.50	3.00	.56	3.25	.88	2.13	2.63
US8AT	5/8	16	1044372	17.5	1047383	3.2	10.59	5.68	1.81	1.63	2.38	5.53	13.19	1.91	1.53	2.88	.75	4.13	.69	3.26	3.50
US8AT	3/4	19	1044381	17.5	1047392	3.4	10.59	5.68	1.81	1.63	2.38	5.84	13.54	2.38	1.53	2.88	.75	4.13	.78	3.12	3.38
US7*	7/8	22	1038580	16.5	1046674	2.6	11.26	5.11	1.31	1.25	2.69	—	—	2.56	1.63	3.26	.66	3.25	1.06	2.12	2.56
US7*	1	25	1038589	16.5	1046683	2.6	11.26	5.11	1.31	1.25	2.69	—	—	2.56	1.63	3.26	.66	3.25	1.06	1.88	2.38
US8T	7/8	22	1044404	20.8	1047425	5.5	12.77	6.96	1.81	1.63	3.06	7.20	16.02	2.87	1.65	3.12	.75	4.13	.88	3.88	4.18
US8T	1	25	1044417	20.8	1047431	6.1	12.77	6.96	1.81	1.63	3.06	7.31	16.41	2.32	1.65	3.12	.75	4.13	1.03	3.76	4.06
US10T	1-1/8	28	1044426	46.5	1047440	9.7	15.94	8.62	1.81	1.63	3.57	9.15	19.72	3.26	2.19	4.38	.75	4.13	1.09	4.76	5.06
US10T	1-1/4	32	1044435	46.5	1047459	10.4	15.94	8.62	1.81	1.63	3.57	9.39	20.22	2.83	2.19	4.38	.75	4.13	1.19	4.62	4.94
US11T	1-1/8	28	1044444	60.6	1047468	12.5	16.34	8.73	2.62	2.50	3.56	9.15	19.97	3.37	2.34	4.50	1.06	6.13	1.09	4.76	5.06
US11T	1-1/4	32	1044453	64.9	1047477	15.0	16.34	8.73	2.62	2.50	3.56	9.39	20.48	2.94	2.34	4.50	1.06	6.13	1.19	4.62	4.94

* Non-Terminator Style.

S-423T

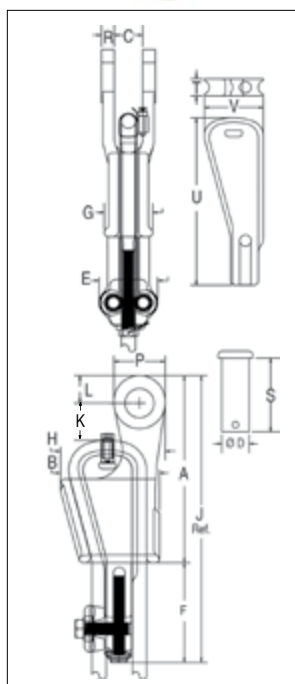

- The 423T wedge socket terminations have a minimum efficiency rating on most high-performance, high-strength, compacted-strand, rotation-resistant wire ropes of 80% based on the catalog breaking strength of the various ropes.
- Design eliminates the difficulty of properly seating the wedge with high performance wire rope into a wedge socket termination.
- Proper application of the Super Terminator eliminates the 'first load' requirement of conventional wedge socket terminations.
- S-423TW Wedge Kit can be retrofitted onto existing Crosby S-421T Terminator Wedge Sockets.
- Wedge and accessories provided with a zinc finish.
- Meets the performance requirements of EN13411-6.
- Meets or exceeds all requirements of ASME B30.26, including identification, ductility, design factor, proof load, and temperature requirements. Importantly, these sockets meet other critical performance requirements, including fatigue life, impact properties, and material traceability not addressed by ASME B30.26.
- Basket is cast steel and individually magnetic particle inspected.
- Pin diameter and jaw opening allows wedge and socket to be used in conjunction with closed swage and spelter sockets.
- Secures the tail or dead end of the wire rope to the wedge, thus eliminates loss or punch out of the wedge.
- Eliminates the need for an extra piece of rope, and is easily installed.
- The Terminator wedge eliminates the potential breaking off of the tail due to fatigue.
- The tail, which is secured by the base of the clip and the tension device, is left undeformed.
- Available with bolt, nut, and cotter pin: S-423TB.
- Available with API-2C certification upon request.
- Wedge sockets meet the performance requirements of Federal Specification RR-S-550F, Type C, except those provisions required of the contractor.
- The S-423T Super Terminator wedge is designed to be assembled only into the Crosby S-421T Terminator socket body. Important: The S-423TW for sizes 5/8" through 1-1/8" will fit respective size standard Crosby S-421T basket. The 1-1/4" S-423TW will only fit the Crosby S-421T 1-1/4" basket marked with Terminator.

Assembly includes socket, wedge, pin, wire rope clip, tensioner, bolts and secondary retention wire.

APPLICATION AND WARNING INFORMATION
SECTION 17

S-423T WEDGE SOCKETS

Wire Rope Dia.		S-423T Assembly with Round Pin and Cotter Pin			S-423TB Assembly with Bolt, Nut and Cotter Pin			S-423TW** Wedge Kit		
		S-423T Stock No.	S-423T Weight Each		S-423TB Stock No.	S-423TB Weight Each		S-423TW Stock No.	S-423TW Weight Each	
(in)	(mm)		(lb)	(kg)		(lb)	(kg)		(lb)	(kg)
5/8	14- 16	1035123	12.7	5.8	1035218	13.1	5.9	1034018	5.2	2.4
3/4	18-19	1035132	19.4	8.8	1035227	19.1	8.7	1034027	7.2	3.3
7/8	20-22	1035141	28.8	13.1	1035236	27.8	12.6	1034036	10.3	4.7
1	24-26	1035150	39.2	17.8	1035245	37.3	16.9	1034045	11.9	5.4
1-1/8	28	1035169	57.1	25.9	1035254	57.9	25.9	1034054	19.9	9.0
1-1/4	30-32	1035178	88.6	40.2	1035272	88.1	39.9	1034063	33.8	15.3

**Kit contains wedge, wire rope clip and bolts, tensioner bolt, and secondary retention wire.

Wire Rope Dia.		S-423T Stock No.	Dimensions (in)																
(in)	(mm)		A	B	C	D	E	F	G	H	J*	K	L	P	R	S	T	U	V
5/8	14- 16	1035123	8.25	4.50	1.25	1.19	3.00	4.06	2.13	4.61	12.31	1.09	1.22	2.25	.56	3.25	.75	6.88	2.60
3/4	18-19	1035132	9.88	5.20	1.50	1.38	3.25	4.81	2.44	5.37	14.69	1.50	1.40	2.62	.66	3.63	.88	7.65	3.02
7/8	20-22	1035141	11.25	5.88	1.75	1.63	3.81	5.73	2.69	6.16	16.98	1.59	1.67	3.13	.75	4.31	1.00	9.47	3.47
1	24-26	1035150	12.81	6.56	2.00	2.00	3.81	5.73	2.94	7.05	18.54	1.44	2.01	3.75	.88	4.70	1.13	10.41	3.82
1-1/8	28	1035169	14.38	6.94	2.25	2.25	4.00	6.85	3.38	7.81	21.23	1.12	2.26	4.25	1.00	5.44	1.25	11.83	4.22
1-1/4	30-32	1035178	16.34	8.63	2.62	2.50	4.50	7.76	3.57	9.38	24.10	1.50	2.34	4.50	1.06	6.62	1.38	13.87	5.82

* Nominal note: For intermediate wire rope sizes, use next larger size socket.

Wire Rope Lubricant

Vitalife® products are the preferred wire rope lubricants in the industry because of their ability to penetrate into wire rope and displace water and contaminants, thus reducing wear and corrosion throughout the rope.

- Available in a variety of container sizes.
- Provides inner strand preservation and lubricity.
- Allows for easy visual inspection of the ropes.
- Reduces the friction between the strands of the wire rope, thus extending rope life.
- Adheres to surface of strands, forming an outer film which provides excellent corrosive protection.
- Non-tacky (will not attract dust)
- Vitalife® in aerosol form is a regulated dangerous good. See MSDS sheet for shipping instructions.
- Vitalife® Bio-Lube has been developed especially for environmentally friendly applications.
- Vitalife® 500 has been developed exclusively for ski lifts and tramways.

7

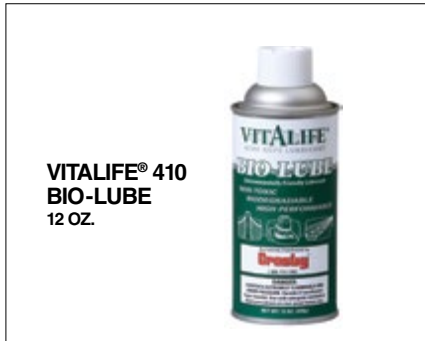

Vitalife® Type	Container Size	Stock No.	Weight Each (kg)
Vitalife® 400 (Standard)	12 Ounce	1038946	1.00
	5 Gallon	1038955	41.0
	55 Gallon	1038964	420
Vitalife® 410 BIO-LUBE (Environmentally Friendly)	12 Ounce	1039004	1.00
	5 Gallon	1039013	41.0
	55 Gallon	1039022	420
Vitalife® 500 (Ski Lifts and Tramways)	5 Gallon	1038973	41.0
	55 Gallon	1038982	420



VSP Vitalife® Spray Applicators

- Designed and manufactured to work in the rugged field conditions of the construction industry.
- All applicator seals are specially designed to work with Vitalife® 400 and BIO-LUBE products.

Description	VSP Stock No.	Weight Each (lb)
4 Gallon Backpack Sprayer	1039092	11.8

SB-427



- Available in six sizes from 1/2" to 1-1/2" (13mm - 38mm).
- Button Spelter terminations have a 100% efficiency rating, based on the catalog strength of the wire rope.
- Designed for use with mobile cranes. Can be used to terminate high performance, rotation resistant ropes, and standard 6 strand ropes.
- Easy to install assembly utilizes Crosby WIRELOCK® socketing compound.
- Sockets and buttons are re-usable.
- Replacement buttons and sockets are available.
- Locking feature available to prevent rotation of rope.
- Button contains cap with eye that can be attached to, and used to pull, rope during reeving process.
- Manufactured to the requirements of API-2C.

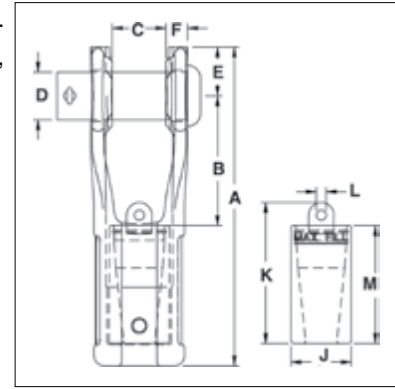

APPLICATION AND WARNING INFORMATION
SECTION 17

SB-427 Button Spelter Sockets

Wire Rope Size		Stock No.	Ultimate Load (t)	Weight Each (lb)	Button Only Stock No.	Dimensions (in)										Tolerance +/-
(in)	(mm)					A	B	C	D	E	F	J	K	L	M	C
1/2 - 5/8	13-16	1052005	27	6.1	1052309	7.94	3.23	1.28	1.19	1.22	.57	1.50	3.50	.25	2.93	.06
5/8 - 3/4	16-19	1052014	45	10.3	1052318	9.44	3.88	1.53	1.38	1.44	.66	1.75	4.28	.38	3.43	.06
3/4 - 7/8	19-22	1052023	57	17.1	1052327	10.81	4.41	1.78	1.62	1.69	.75	2.06	4.78	.38	3.96	.06
7/8 - 1	22-26	1052032	82	29.2	1052336	12.88	5.48	2.03	2.00	2.00	.89	2.44	5.62	.62	4.52	.09
1-1/8 - 1-1/4	28-32	1052041	136	46.0	1052345	14.90	5.68	2.53	2.25	2.50	1.11	2.94	7.08	.75	5.72	.09
1-3/8 - 1-1/2	35-38	1052050	161	78.0	1052354	18.06	7.17	3.03	2.75	2.75	1.24	3.62	8.08	.75	6.76	.09

SB-427TB (Bolt, Nut and Cotter Pin)

Wire Rope Size		Stock No.	Ultimate Load (t)	Weight Each (lb)	Button Only Stock No.	Dimensions (in)										Tolerance +/-
(in)	(mm)					A	B	C	D	E	F	J	K	L	M	C
1/2 - 5/8	13-16	1052406	27	6.1	1052309	7.94	3.23	1.28	1.19	1.22	.57	1.50	3.50	.25	2.93	.06
5/8 - 3/4	16-19	1052415	45	10.3	1052318	9.44	3.88	1.53	1.38	1.44	.66	1.75	4.28	.38	3.43	.06
3/4 - 7/8	19-22	1052424	57	17.1	1052327	10.81	4.41	1.78	1.62	1.69	.75	2.06	4.78	.38	3.96	.06
7/8 - 1	22-26	1052433	82	29.2	1052336	12.88	5.48	2.03	2.00	2.00	.89	2.44	5.62	.62	4.52	.09
1-1/8 - 1-1/4	28-32	1052442	136	46.0	1052345	14.90	5.68	2.53	2.25	2.50	1.11	2.94	7.08	.75	5.72	.09
1-3/8 - 1-1/2	35-38	1052451	161	78.0	1052354	18.06	7.17	3.03	2.75	2.75	1.24	3.62	8.08	.75	6.76	.09

Wirelock® Requirements

Wire Rope Size		WIRELOCK Required	WIRELOCK Stock No.	WIRELOCK Kit Size
(in)	(mm)	(cc)		(cc)
1/2 - 5/8	13-16	35	1039602	100
5/8 - 3/4	16-19	60	1039602	100
3/4 - 7/8	19-22	100	1039602	100
7/8 - 1	22-26	140	1039602*	100
1-1/8 - 1-1/4	28-32	250	1039604	250
1-3/8 - 1-1/2	35-38	420	1039606	500

* 2 kits required.

G-416 / S-416



- Forged steel sockets through 1-1/2", cast alloy steel 1-5/8" through 4".
- Spelter socket terminations have an efficiency rating of 100%, based on the catalog strength of wire rope.
- Ratings are based on recommended use with 6 x 7, 6 x 19 or 6 x 37, IPS or XIP (EIP), XXIP (EEIP), RRL, FC or IWRC wire rope.
- Strand constructed with minimal number of wires (e.g. 1 x 7) requires special consideration that socket basket length be five (5) times the strand diameter or fifty (50) times the wire diameter, whichever is the greater.
- All cast steel sockets 1-5/8" and larger are magnetic particle inspected and ultrasonic inspected. Proof testing available on special order.
- Available with bolt nut and cotter: G-416B.
- Open Grooved Sockets meet the performance requirements of Federal Specification RR-S-550F, Type A, except for those provisions required of the contractor.

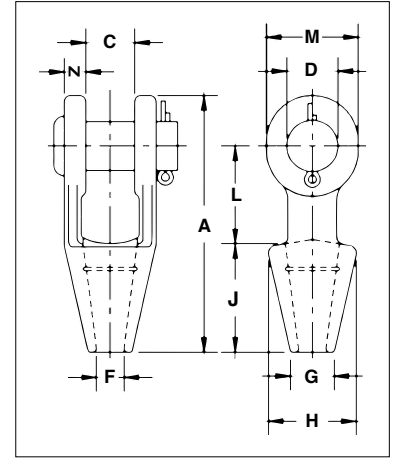

G-416 / S-416 Open Spelter Sockets

Rope Dia.		Structural Strand Dia. (in)	Ultimate Load (t)	Stock No.		Weight Each (lb)	Dimensions (in)										Tolerance +/-
(in)	(mm)			G-416 Galv.	S-416 S.C.		A	C	D	F	G	H	J	L	M	N	
5/16-3/8	8-10	—	12	1039637	1039646	1.30	4.84	.81	.81	.50	.81	1.69	2.25	1.75	1.50	.44	.06
7/16-1/2	11-13	—	20	1039655	1039664	2.25	5.56	1.00	1.00	.56	.94	1.88	2.50	2.00	1.88	.50	.06
9/16-5/8	14-16	1/2	27	1039673	1039682	3.60	6.75	1.25	1.19	.69	1.13	2.25	3.00	2.50	2.25	.64	.06
3/4	18	9/16-5/8	43	1039691	1039708	5.83	7.94	1.50	1.38	.81	1.25	2.62	3.50	3.00	2.62	.62	.06
7/8	20-22	11/16-3/4	55	1039717	1039726	9.65	9.25	1.75	1.63	.94	1.50	3.25	4.00	3.50	3.13	.80	.06
1	24-26	13/16-7/8	78	1039735	1039744	15.50	10.56	2.00	2.00	1.13	1.75	3.75	4.50	4.00	3.75	.88	.06
1-1/8	28-30	15/16-1	92	1039753	1039762	21.50	11.81	2.25	2.25	1.25	2.00	4.12	5.00	4.62	4.12	1.00	.12
1-1/4 - 1-3/8	32-35	1-1/16 - 1-1/8	136	1039771	1039780	31.00	13.19	2.50	2.50	1.50	2.25	4.75	5.50	5.00	4.75	1.13	.12
1-1/2	38	1-3/16 - 1-1/4	170	1039799	1039806	47.25	15.12	3.00	2.75	1.63	2.75	5.25	6.00	6.00	5.38	1.19	.12
* 1-5/8	* 40-42	1-5/16 - 1-3/8	188	1039815	1039824	55.00	16.25	3.00	3.00	1.75	3.00	5.50	6.50	6.50	5.75	1.31	.12
* 1-3/4 - 1-7/8	* 44-48	1-7/16 - 1-5/8	268	1039833	1039842	82.00	18.25	3.50	3.50	2.00	3.13	6.38	7.50	7.00	6.50	1.56	.12
* 2 - 2-1/8	* 50-54	1-11/16 - 1-3/4	291	1039851	1039860	129.00	21.50	4.00	3.75	2.25	3.75	7.38	8.50	9.00	7.00	1.81	.12
* 2-1/4 - 2-3/8	* 56-60	1-13/16 - 1-7/8	360	1039879	1039888	167.00	23.50	4.50	4.25	2.50	4.00	8.25	9.00	10.00	7.75	2.13	.12
* 2-1/2 - 2-5/8	* 64-67	1-15/16 - 2-1/8	424	1041633	1041642	252.00	25.50	5.00	4.75	2.88	4.50	9.25	9.75	10.75	8.50	2.38	.12
* 2-3/4 - 2-7/8	* 70-73	2-3/16 - 2-7/16	511	1041651	1041660	315.00	27.25	5.25	5.00	3.12	4.88	10.50	11.00	11.00	9.00	2.88	.25
* 3 - 3-1/8	* 75-80	2-1/2 - 2-5/8	563	1041679	1041688	380.00	29.00	5.75	5.25	3.38	5.25	11.12	12.00	11.25	9.50	3.00	.25
* 3-1/4 - 3-3/8	* 82-86	2-3/4 - 2-7/8	722	1041697	1041704	434.00	30.88	6.25	5.50	3.62	5.75	11.88	13.00	11.75	10.00	3.12	.25
* 3-1/2 - 3-5/8	* 88-92	3 - 3-1/8	779	1041713	1041722	563.00	33.25	6.75	6.00	3.88	6.50	12.38	14.00	12.50	10.75	3.25	.25
* 3-3/4 - 4	* 94-102	—	875	1041731	1041740	783.00	36.25	7.50	7.00	4.25	7.25	13.62	15.00	13.50	12.50	3.50	.25

* Cast alloy steel.

G-417 / S-417



- Forged steel sockets through 1-1/2", cast alloy steel 1-5/8" through 4".
- Spelter socket terminations have an efficiency rating of 100%, based on the catalog strength of wire rope.
- Ratings are based on recommended use with 6 x 7, 6 x 19, or 6 x 37, IPS or XIP (EIP), XXIP (EEIP), RRL, FC, or IWRC wire rope.
- Strand constructed with minimal number of wires (e.g. 1 x 7) requires special consideration that socket basket length be five (5) times the strand diameter or fifty (50) times the wire diameter, whichever is the greater.
- All cast steel sockets 1-5/8" and larger are magnetic particle inspected and ultrasonic inspected. Proof testing available on special order.
- Closed Grooved Sockets meet the performance requirements of Federal Specification RR-S-550F, Type B, except for those provisions required of the contractor.

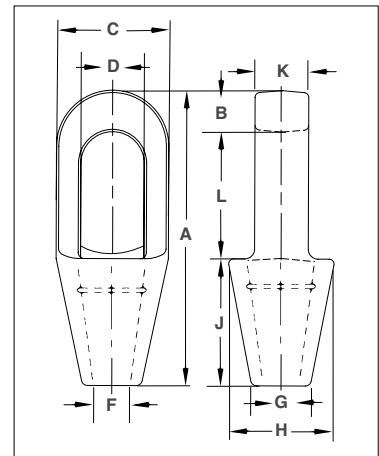

G-417 / S-417 Closed Spelter Sockets

Rope Dia.		Structural Strand Dia. (in)	Ultimate Load (t)	Stock No.		Weight Each (lb)	Dimensions (in)									
(in)	(mm)			G-417 Galv.	S-417 S.C.		A	B	C	D*	F	G	H	J	K	L
5/16 - 3/8	8-10	—	12.0	1039913	1039922	.75	4.94	.62	1.69	.97	.50	.81	1.69	2.25	.69	2.06
7/16 - 1/2	11-13	—	20.0	1039931	1039940	1.50	5.50	.69	2.00	1.16	.56	.94	2.00	2.50	.88	2.31
9/16 - 5/8	14-16	1/2	30.8	1039959	1039968	2.50	6.31	.81	2.63	1.41	.69	1.12	2.38	3.00	1.00	2.50
3/4	18	9/16 - 5/8	43.5	1039977	1039986	4.25	7.62	1.06	3.00	1.66	.88	1.25	2.75	3.50	1.25	3.06
7/8	20-22	11/16 - 3/4	65.3	1039995	1040000	7.25	8.75	1.25	3.63	1.94	1.00	1.50	3.25	4.00	1.50	3.50
1	24-26	13/16 - 7/8	81.6	1040019	1040028	10.50	9.91	1.41	4.13	2.30	1.13	1.75	3.75	4.50	1.75	4.00
1-1/8	28-30	15/16 - 1	100	1040037	1040046	14.25	11.00	1.50	4.50	2.56	1.25	2.00	4.13	5.00	2.00	4.50
1-1/4 - 1-3/8	32-35	1-1/16 - 1-1/8	136	1040055	1040064	19.75	12.12	1.63	5.00	2.81	1.50	2.25	4.75	5.50	2.25	5.00
1-1/2	38	1-3/16 - 1-1/4	170	1040073	1040082	29.20	13.94	1.94	5.38	3.19	1.63	2.75	5.25	6.00	2.50	6.00
† 1-5/8	† 40-42	1-5/16 - 1-3/8	188	1040091	1040108	36.00	15.13	2.13	5.75	3.25	1.75	3.00	5.50	6.50	2.75	6.50
† 1-3/4 - 1-7/8	† 44-48	1-7/16 - 1-5/8	268	1040117	1040126	57.25	17.25	2.19	6.75	3.75	2.00	3.13	6.38	7.50	3.00	7.56
† 2 - 2-1/8	† 50-54	1-11/16 - 1-3/4	309	1040135	1040144	79.00	19.87	2.44	7.63	4.38	2.25	3.75	7.38	8.50	3.25	8.81
† 2-1/4 - 2-3/8	† 56-60	1-13/16 - 1-7/8	360	1040153	1040162	105.00	21.50	2.75	8.50	5.00	2.63	4.13	8.25	9.00	3.63	9.75
† 2-1/2 - 2-5/8	† 64-67	1-15/16 - 2-1/8	424	1041759	1041768	140.00	23.50	3.12	9.50	5.50	2.88	4.50	9.25	9.75	4.00	10.62
† 2-3/4 - 2-7/8	† 70-73	2-3/16 - 2-7/16	549	1041777	1041786	220.00	25.38	3.12	10.75	6.25	3.12	4.88	10.19	11.00	4.88	11.25
† 3 - 3-1/8	† 75-80	2-1/2 - 2-5/8	656	1041795	1041802	276.00	27.12	3.37	11.50	6.75	3.38	5.25	11.50	12.00	5.25	11.75
† 3-1/4 - 3-3/8	† 82-86	2-3/4 - 2-7/8	750	1041811	1041820	313.00	29.25	4.00	12.25	7.25	3.62	5.75	12.25	13.00	5.75	12.25
† 3-1/2 - 3-5/8	† 88-92	3 - 3-1/8	820	1041839	1041848	400.00	31.00	4.00	13.00	7.75	3.88	6.31	13.00	14.00	6.25	13.00
† 3-3/4 - 4	† 94 - 102	—	1005	1041857	1041866	542.00	33.25	4.25	14.25	8.50	4.25	7.25	14.25	15.00	7.00	14.00

* Diameter of pin must not exceed pin used on companion 416 socket. Reference adjacent page "D" dimension. † Cast alloy steel.

RESIN FOR SPELTER SOCKETS

Note: For use on 416, 417, 427 and 517 spelter sockets only.



WIRELOCK®
Socketing Compound

- 100% termination efficiency.
- Temperature operating range is -65° F to +240° F (-54°C to +116°C).
- Ideal for on-site applications.
- No hazardous molten metal.
- Improved fatigue life.
- Pouring temperature without booster pack is 48° F to 110° F (6.67°C to 43.3°C).
- One booster pack if pouring temperature is 35° F to 48° F (1.67°C to 8.89°C).
- Two booster packs if pouring temperature is 27° F to 35° F (-2.78°C to +1.67°C).
- Refer to Crosby® Wire Rope End Terminations Manual for more information.
- Storage temperature is 68° F (20°C) max. Store in well ventilated area away from sunlight and sources of ignition.



7

APPROVALS:

Lloyds Register of Shipping

Det Norske Veritas (DNV)

United States Coast Guard

Registro Italiano Navale

Germanischer Lloyd

United States Navy

American Bureau of Shipping

ISO 17.558

DNV-OS-E304



U.S. Department of Transportation
United States Coast Guard



WIRELOCK® W416-7 Socket Compound

W416-7 Kits				Booster Pak Stock No.
Kit Size	Kit Per Case	Stock No.	Weight Each (lb)	
100	20	1039602	.62	1039603
250	12	1039604	1.25	1039605
500	12	1039606	2.54	1039607
1000	12	1039608	4.59	1039609
2000	6	1039610	9.00	1039611

Guide to amount WIRELOCK® Required

Wire Rope Size		WIRELOCK Required (cc)	Wire Rope Size		WIRELOCK Required (cc)
(in)	(mm)		(in)	(mm)	
1/4	6-7	9	1-3/4	44	700
5/16	8	17	1-7/8	48	700
3/8	9-10	17	2	51	1265
7/16	11	35	2-1/8	54	1265
1/2	13	35	2-1/4	56	1410
9/16	14	52	2-3/8	60	1410
5/8	16	52	2-1/2	64	1830
3/4	20	86	2-5/8	67	1830
7/8	22	125	2-3/4	70	2250
1	26	160	3	76	3160
1-1/8	28	210	3-1/4	82	3795
1-1/4	32	350	3-1/2	88	4920
1-3/8	36	350	3-3/4	94	5980
1-1/2	40	420	4	102	7730
1-5/8	42	495	—	—	—

Wirelock is a hazardous material regulated by US DOT, ICAO/IATA and IMO for transportation.

Witnessed and tested by American Bureau of Shipping. (ABS)

Approximate U.S. Measurements:
250cc's Kit 1 Cup

APPLICATION AND WARNING INFORMATION
SECTION 17

S-505 Swaging Sleeve

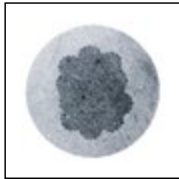

Cross Section of Swaged Sleeve

- For flemish eye wire rope splicing.
- Designed for low temperature toughness.
- Resists cracking when swaged (equals or exceeds stainless steel sleeves).
- Special processed low carbon steel.
- COLD TUFF® for better swageability.
- Can be stamped for identification after swaging without concern for fractures when following these directions:
 - Use round corner stamps to a maximum depth of 0.015 in. (1/64).
 - The area for stamping should be on the side of the sleeve in the plane of the sling eye, and no less than 0.250 in. (1/4) from either end of the sleeve.
- Standard steel sleeve terminations have efficiency ratings as follows based on the catalog strength of wire rope.
- Do not use on wire rope size other than size shown.

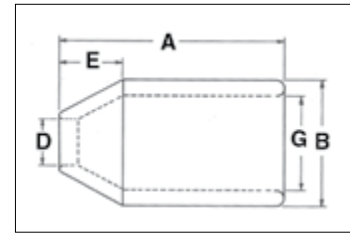

S-505 Termination Efficiency		
Size (in)	Type of Wire Rope *	
	IWRC	FC
1/4 - 1	96%	93%
1-1/8 - 2	92%	89%
2-1/4 and Larger	90%	87%

Intermediate Metric Die Chart

Sleeve and Swaging Die Requirements for Intermediate Sizes of Metric Wire Rope							
S-505 Stock No.	S-505 Sleeve Size	Metric Wire Rope Size (mm)	Standard Round Dies				Maximum After Swage Dimension (in)
			1st Stage Die		2nd Stage Die		
			Die No.	Die Size	Die No.	Die Size	
1041143	1/2	12	1190881	5 x 7 Double Cavity	—	—	.990
1041223	7/8	20	1190901	5 x 7 Double Cavity	—	—	1.620
1041241	1	24	1190921	5 x 7 Double Cavity	—	—	1.880
1041321	1-1/2	36	1192649	5 x 7	1190941	5 x 7	2.630
1041349	1-3/4	40	1192685	5 x 7	1190961	5 x 7	2.950
1041367	2	48	1192729	5 x 7	1190971	5 x 7	3.460
1041401	2-1/2	60	1192809	5 x 7	1190981	5 x 7	4.370
1041401	2-1/2	60	1191061	6 x 12	1190991	6 x 12	4.370
1041447	3	72	1193201	6 x 12	1191001	6 x 12	4.810
1041483	3-1/2	80	1193247	6 x 12	1191101	6 x 12	5.450
1041483	3-1/2	84	1193247	6 x 12	1191121	6 x 12	5.550

QUIC-PASS® system not available for these metric rope sizes. Note: Fittings designed only to be used on exact sizes listed.

** NOTE: S-505 Standard Sleeves are recommended for use with 6 x 19 or 6 x 37, IPS or XIP (EIP), XXIP (EEIP), RRL, FC or IWRC wire rope.

Before using any National Swage fitting with any other type lay, construction or grade of wire rope, it is recommended that the termination be destructive and documented to prove the adequacy of the assembly to be manufactured.

S-505 COLD TUFF® Standard Steel Sleeves

S-505 Standard Steel Sleeve Specifications												Swager / Die Data		
S-505 Stock No.	Rope Size		Weight Per 100 (lb)	Pkg. Qty.	Before Swage Dimensions (in)					Maximum After Swage Dimensions (in)		Standard Round Dies		QUIC-PASS® Dies
	(in)	(mm)			A	B	D	E	G	Standard Die	QUIC-PASS Die	Die Description	Standard Die Stock No.	QUIC-PASS Die Stock No.
1041063	1/4	6-7	5	250	1	.66	.31	.28	.47	.57	.565	1/4 Taper	1197528	1923530
1041090	5/16	8	14	200	1.5	.91	.44	.44	.62	.75	.769	3/8 Taper	1192364	1923551
1041107	3/8	9-10	14	100	1.5	.91	.47	.39	.66	.75	.769	3/8 Taper	1192364	1923551
1041125	7/16	11	33	50	2	1.22	.55	.65	.85	1.01	1.016	1/2 Taper	1192408	1923572
1041143	1/2	13	29	50	2	1.22	.63	.56	.91	1.01	1.016	1/2 Taper	1192408	1923572
1041161	9/16	14	64	25	2.75	1.47	.69	.63	1.03	1.24	1.247	5/8 Taper	1192444	1923593
1041189	5/8	16	56	25	2.75	1.47	.75	.63	1.09	1.24	1.247	5/8 Taper	1192444	1923593
1041205	3/4	18-19	88	20	3.19	1.72	.91	.84	1.28	1.46	1.475	3/4 Taper	1192462	1923614
1041223	7/8	22	131	10	3.56	2.03	1.03	1.00	1.53	1.68	1.738	7/8 Taper	1192480	1923635
1041241	1	25-26	195	10	4	2.28	1.16	1.13	1.72	1.93	1.955	1 Taper	1192505	1923656
1041269	1-1/8	28-29	260	Bulk	4.81	2.50	1.28	1.25	1.94	2.13	2.170	1-1/8 Open 1st Stage 2nd Stage	1192523 1192541	1923677
1041287	1-1/4	31-32	355	Bulk	5.19	2.78	1.44	1.41	2.16	2.32	2.405	1-1/4 Open 1st Stage 2nd Stage	1192621 1192587	1923698
1041303	1-3/8	34-35	423	Bulk	5.81	3.00	1.56	1.56	2.38	2.52	2.610	1-3/8 Open 1st Stage 2nd Stage	1192667 1192621	1923717
1041321	1-1/2	37-38	499	Bulk	6.25	3.25	1.69	1.69	2.63	2.71	2.835	1-1/2 Open 1st Stage 2nd Stage	1192649 1192667	1923736

Note: Fittings designed only to be used on exact sizes listed.

7

S-505 COLD TUFF® Standard Steel Sleeves

S-505 Standard Steel Sleeve Specifications											Swager / Die Data					
S-505 Stock No.	Rope Size		Weight Per 100 (lb)	Pkg. Qty.	Before Swage Dimensions (in)					Maximum After Swage Dimensions (in)	Die Description	Stock No.				
	(in)	(mm)			A	B	D	E	G			500 Tons 1000 Tons 1500 Tons 5x7	Front Load		Side Load	
											1500 Ton 6x12	3000 Ton 6x12	1500 Ton 6x12	3000 Ton 6x12		
1041349	1-3/4	44-45	805	Bulk	7.25	3.84	1.94	1.97	3.13	3.10	1-3/4 Open 1st Stage 2nd Stage	1192685 1192701	—	—	—	—
1041367	2	50-52	1132	Bulk	8.5	4.38	2.25	2.25	3.63	3.56	2 Open 1st Stage 2nd Stage	1192729 1192747	—	—	—	—
1041385	2-1/4	56-57	1936	Bulk	9.56	5.03	2.50	2.53	4.03	4.12	2-1/4 Open 1st Stage 2nd Stage	1192765 1192783	1191089 1191043	1191089 1191043	—	1195085 1195067
1041401	2-1/2	62-64	2352	Bulk	10.5	5.50	2.75	2.81	4.50	4.50	2-1/2 Open 1st Stage 2nd Stage	—	1191061 1191089	1191061 1191089	1195370 1195469	1195076 1195085
1041429	2-3/4	68-70	2800	Bulk	11.5	5.75	3.00	3.09	4.75	4.70	2-3/4 Open 1st Stage 2nd Stage	—	1191034 1191052	1191034 1191052	1195389 1195478	1195094 1195101
1041447	3	75-76	2940	Bulk	12	6.00	3.25	3.38	5.00	4.96	3 Open 1st Stage 2nd Stage	—	1193201 1193229	1193201 1193229	1195398 1195487	1195110 1195129
1041483	3-1/2	87-89	4640	Bulk	14	7.00	3.88	3.94	5.84	5.77	3-1/2 Open 1st Stage 2nd Stage	—	1193247 1193265	1193247 1193265	—	1195138 1195147
1041492	3-3/4	93-95	5500	Bulk	15	7.50	4.06	4.25	6.31	6.23	3-3/4 Open 1st Stage 2nd Stage	—	—	1191114 1191132	—	1195263 1195272
1041508	4	100-105	6800	Bulk	16	8.13	4.38	4.50	6.81	6.69	4 Open 1st Stage 2nd Stage	—	—	1191150 1191178	—	1195156 1195165
1041526	4-1/2	112-114	10000	Bulk	18	9.13	4.88	5.06	7.66	7.45	4-1/2 Open 1st Stage 2nd Stage	—	—	1191187 1191203	—	1195174 1195183

Note: Fittings designed only to be used on exact sizes listed.

S-501



- Forged from special bar quality carbon steel, suitable for cold forming.
- Swage socket terminations have an efficiency rating of 100% based on the catalog strength of wire rope.
- Hardness controlled by spheroidize annealing.
- Stamp for identification after swaging without concern for fractures (as per directions in Wire Rope End Terminations User's Manual).
- Swage sockets incorporate a reduced machined area of the shank which is equivalent to the proper 'after swage' dimension. Before swaging, this provides for an obvious visual difference in the shank diameter. After swaging, a uniform shank diameter is created allowing for a QUIC-CHECK® and permanent visual inspection opportunity.
- S-501 Swage Sockets are recommended for use with 6 x 19 or 6 x 37, IPS or XIP (EIP), XXIP (EEIP), RRL, FC or IWRC wire rope.
- In accordance with ASME B30.9, all slings terminated with swage sockets shall be proof loaded.*

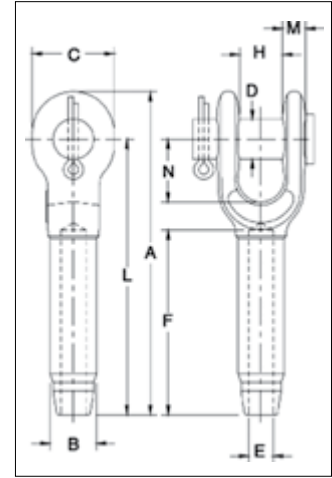

S-501 Open Swage Sockets

S-501 and S-501B Open Socket Specifications																	Swager / Die Data					
S-501 Stock No.	S-501B Stock No. †	Rope Size		Wt. Each (lb)	Ultimate Load** (t)	Before Swage Dimensions (in)										Tolerance +/-	Max. After Swage Dim. (in)	Die Description	Stock No.		Side Load	
		(in)	(mm)			A	B	C	D	E	F	H	L	M	N				H	500 Ton 5 x 7	1500 Ton 6 x 12	1500 Ton 6 x 12
1039021	1054001	1/4	6	.52	5.4	4.78	.50	1.38	.69	.27	2.19	.69	4.00	.38	1.47	.06	.46	1/4 Socket	1192845	-	-	-
1039049	1054010	5/16	8	1.12	11.8	6.3	.78	1.62	.81	.34	3.25	.80	5.34	.48	1.67	.06	.71	5/16-3/8 Socket	1192863	-	-	-
1039067	1054029	3/8	9-10	1.30	13.6	6.3	.78	1.62	.81	.41	3.25	.80	5.34	.48	1.67	.06	.71	5/16-3/8 Socket	1192863	-	-	-
1039085	1054038	7/16	11-12	2.08	18.1	7.82	1.01	2.00	1.00	.49	4.31	1.00	6.69	.56	1.96	.06	.91	7/16-1/2 Socket	1192881	-	-	-
1039101	1054047	1/2	13	2.08	21.3	7.82	1.01	2.00	1.00	.55	4.31	1.00	6.69	.56	1.96	.06	.91	7/16-1/2 Socket	1192881	-	-	-
1039129	1054056	9/16	14	4.67	31.8	9.54	1.27	2.38	1.19	.61	5.38	1.25	8.13	.68	2.21	.06	1.16	9/16-5/8 Socket	1192907	-	-	-
1039147	1054065	5/8	16	4.51	34.9	9.54	1.27	2.38	1.19	.68	5.38	1.25	8.13	.68	2.21	.06	1.16	9/16-5/8 Socket	1192907	-	-	-
1039165	1054074	3/4	18-20	7.97	43.5	11.61	1.56	2.75	1.38	.80	6.44	1.50	10.00	.80	2.69	.06	1.42	3/4 Socket	1192925	-	-	-
1039183	1054083	7/8	22	11.52	51.5	13.37	1.72	3.13	1.63	.94	7.50	1.75	11.63	.94	3.20	.07	1.55	7/8 Socket	1192943	-	-	-
1039209	1054092	1	24-26	17.80	71.4	15.47	2.00	3.69	2.00	1.07	8.63	2.00	13.38	1.07	3.68	.08	1.80	1 Socket	1192961	-	-	-
1039227	1054104	1-1/8	28	25.25	83.3	17.35	2.25	4.12	2.25	1.19	9.63	2.25	15.00	1.19	4.18	.10	2.05	1-1/8 Socket	1192989	-	-	-
1039245	1054113	1-1/4	32	35.56	109	19.2	2.53	4.59	2.50	1.34	10.69	2.50	16.50	1.27	4.68	.10	2.30	1-1/4 Socket	1193005	-	-	-
1039263	1054122	1-3/8	34-36	43.75	136	21.1	2.81	5.25	2.50	1.46	11.88	2.41	18.13	1.46	5.25	.10	2.56	1-3/8 Socket	1193023	-	-	-
1039281	1054131	1-1/2	38-40	58.50	181	23.17	3.08	5.50	2.75	1.59	12.81	3.00	19.75	1.70	5.70	.10	2.81	1-1/2 Socket	1193041	1191267	1195355	1195192
1039307	1054140	1-3/4	44	88.75	228	26.7	3.40	6.25	3.50	1.87	15.06	3.50	23.00	2.11	6.67	.10	3.06	1-3/4 Socket	1193069	1191276	1195367	1195209
1042767	1054159	2	48-52	146.2	272	31.15	3.94	7.80	3.75	2.12	17.06	4.00	26.75	1.81	8.19	.10	3.56	2 Socket	1193087	1191294	1195379	1195218

*Maximum Proof Load shall not exceed 50% of XXIP rope catalog breaking strength. ** The Ultimate Loads of 3/4" through 1 1/4" sizes have been increased to meet the requirements for 8 strand 2160 Grade pendants. † Assembly with bolt, nut and cotter pin. Note: Fittings designed only to be used on exact sizes listed. NOTE: Before using any Crosby fitting with any other type lay, construction or grade of wire rope, it is recommended that the termination be destructive tested and documented to prove the adequacy of the assembly to be manufactured.

S-502



- Forged from special bar quality carbon steel, suitable for cold forming.
- Swage socket terminations have an efficiency rating of 100% based on the catalog strength of wire rope.
- Hardness controlled by spheroidize annealing.
- Stamp for identification after swaging without concern for fractures (as per directions in Wire Rope End Terminations User's Manual).
- Swage sockets incorporate a reduced machined area of the shank which is equivalent to the proper 'after swage' dimension. Before swaging, this provides for an obvious visual difference in the shank diameter. After swaging, a uniform shank diameter is created allowing for a QUIC-CHECK® and permanent visual inspection opportunity.
- S-502 Swage Sockets are recommended for use with 6 x 19 or 6 x 37, IPS or XIP (EIP), XXIP (EEIP), RRL, FC or IWRC wire rope.
- In accordance with ASME B30.9, all slings terminated with swage sockets shall be proof loaded.*

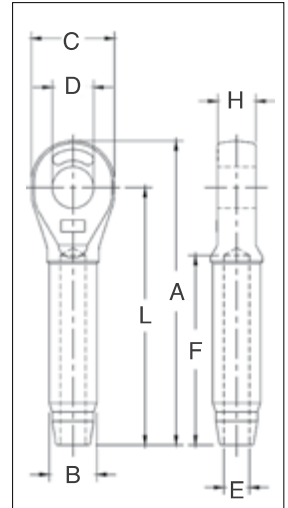

S-502 Closed Swage Sockets

S-502 Stock No.	Rope Size		S-502 Closed Socket Specifications											Max. After Swage Dim. (in)	Swager / Die Data					
			Wt. Each (lb)	Ultimate Load** (t)	Before Swage Dimensions (in)										Die Description	Stock No.		Side Load		
					A	B	C	D	E	F	H	L	500 1000 1500 Ton 5 x 7			1500 3000 Ton 6 x 12	1500 Ton 6 x 12	3000 Ton 6 x 12		
1039325	1/4	6	.33	5.4	4.28	.50	1.38	.76	.27	2.19	.50	3.50	.46	1/4 Socket	1192845	-	-	-		
1039343	5/16	8	.75	11.8	5.42	.77	1.62	.88	.34	3.25	.68	4.50	.71	5/16-3/8 Socket	1192863	-	-	-		
1039361	3/8	9-10	.72	13.6	5.42	.78	1.62	.88	.41	3.25	.68	4.50	.71	5/16-3/8 Socket	1192863	-	-	-		
1039389	7/16	11-12	1.42	18.1	6.88	1.01	2.00	1.07	.49	4.31	.87	5.75	.91	7/16-1/2 Socket	1192881	-	-	-		
1039405	1/2	13	1.42	21.3	6.88	1.01	2.00	1.07	.55	4.31	.87	5.75	.91	7/16-1/2 Socket	1192881	-	-	-		
1039423	9/16	14	2.92	31.8	8.59	1.27	2.38	1.28	.61	5.38	1.14	7.25	1.16	9/16-5/8 Socket	1192907	-	-	-		
1039441	5/8	16	2.85	34.9	8.59	1.27	2.38	1.28	.68	5.38	1.14	7.25	1.16	9/16-5/8 Socket	1192907	-	-	-		
1039469	3/4	18-20	5.00	43.5	10.25	1.56	2.88	1.49	.80	6.44	1.33	8.63	1.42	3/4 Socket	1192925	-	-	-		
1039487	7/8	22	6.80	51.5	11.87	1.72	3.12	1.73	.94	7.50	1.53	10.09	1.55	7/8 Socket	1192943	-	-	-		
1039502	1	24-26	10.40	71.4	13.56	2.00	3.62	2.11	1.07	8.63	1.78	11.50	1.80	1 Socket	1192961	-	-	-		
1039520	1-1/8	28	14.82	83.3	15.03	2.25	4.00	2.37	1.19	9.75	2.03	12.75	2.05	1-1/8 Socket	1192989	-	-	-		
1039548	1-1/4	32	21.57	109	16.94	2.53	4.50	2.62	1.34	10.81	2.25	14.38	2.30	1-1/4 Socket	1193005	-	-	-		
1039566	1-3/8	34-36	28.54	136	18.59	2.81	5.00	2.62	1.46	11.88	2.29	15.75	2.56	1-3/8 Socket	1193023	-	-	-		
1039584	1-1/2	38-40	38.06	181	20.13	3.08	5.38	2.87	1.59	12.81	2.56	17.00	2.81	1-1/2 Socket	1193041	1191267	1195355	1195192		
1039600	1-3/4	44	51.00	228	23.56	3.40	6.25	3.63	1.87	15.06	3.08	20.00	3.06	1-3/4 Socket	1193069	1191276	1195367	1195209		
1042589	2	48-52	89.25	272	27.13	3.94	7.25	3.88	2.12	17.06	3.31	23.00	3.56	2 Socket	1193087	1191294	1195379	1195218		

Maximum Proof Load shall not exceed 50% of XXIP rope catalog breaking strength. *The Ultimate Loads of 3/4" through 1 1/4" sizes have been increased to meet the requirements for 8 strand 2160 Grade pendants. Note: Fittings designed only to be used on exact sizes listed.

NOTE: Before using any Crosby fitting with any other type lay, construction or grade of wire rope, it is recommended that the termination be destructive tested and documented to prove the adequacy of the assembly to be manufactured.

S-409



- Swage button terminations have an efficiency rating of 98% based on the catalog strength of wire rope.
- Special processed, low carbon steel.
- COLD TUFF® for better swageability.
- Stamp for identification after swaging without concern for fractures (as per directions in the Wire Rope End Terminations User's Manual).
- S-409 Buttons are recommended for use with 6 x 19 or 6 x 37, IPS or XIP (EIP), RRL, FC or IWRC wire rope. Before using any National Swage fitting with any other type lay, construction or grade of wire rope, it is recommended that the termination be destructive tested and documented to prove the adequacy of the assembly to be manufactured.

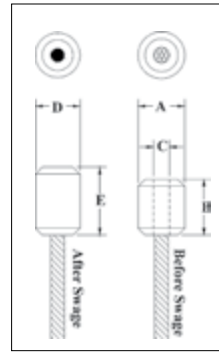

S-409 COLD TUFF® Buttons

S-409 Steel Swage Button Specifications										Swager / Die Data	
S-409 Stock No.	Size No.	Rope Size		Weight Per 100 (lb)	Before Swage Dimensions (in)			After Swage Dimensions (in)		Die Description	Stock No. 500 Tons 1000 Tons 1500 Tons 5 x 7
		(in)	(mm)		A	B	C	D Maximum After Swage Dimensions	E Length*		
1040171	1 SB	1/8	3	2	.42	.50	.14	.40	.61	1/8 - 1/4 Button	1191621
1040215	3 SB	3/16	5	4	.56	.70	.20	.52	.84	1/4 1st Stage	1197528
1040251	5 SB	1/4	6-7	8	.68	1.06	.31	.58	1.41	1/8 - 1/4 Button	1191621
1040297	7 SB	5/16	8	16	.88	1.13	.36	.77	1.33	3/8 1st Stage	1192364
1040313	8 SB	3/8	9-10	15	.88	1.48	.42	.77	1.69	3/8 1st stage	1192364
1040331	9 SB	7/16	11	30	1.13	1.63	.48	1.03	1.94	1/2 1st Stage	1192408
1040359	10 SB	1/2	13	50	1.31	1.89	.55	1.16	2.17	5/8 Socket	1192907
1040377	11 SB	9/16	14	70	1.44	2.02	.61	1.29	2.41	9/16 - 5/8 Button	1191665
1040395	12 SB	5/8	16	100	1.56	2.42	.67	1.42	2.89	3/4 Socket	1192925
1040411	13 SB	3/4	18-20	131	1.68	2.74	.80	1.55	3.25	3/4 1st Stage	1192462
1040439	14 SB	7/8	22	220	2	3.27	.94	1.80	3.86	7/8 1st Stage	1192480
1040457	15 SB	1	25-26	310	2.25	3.67	1.06	2.05	4.36	1 1st Stage	1192505
1040475	16 SB	1-1/8	28-29	450	2.56	4.05	1.19	2.30	4.81	1-1/8 1st Stage	1192523
1040493	17 SB	1-1/4	31-32	650	2.81	4.57	1.33	2.56	5.42	1-3/8 Socket	1193023

* NOTE: Length is measured from outside end of termination. Fittings designed only to be used on exact sizes listed.

S-506



- For turnback wire rope splicing.
- Special processed low carbon steel.
- Turnback terminations have efficiency ratings of 94% based on the catalog strength of wire rope.
- COLD TUFF® for better swageability and low temperature toughness.
- S-506 Sleeves are recommended for use with 6 x 19 or 6 x 37, IPS or XIP (EIP), RRL, FC or IWRC wire rope. Before using any National Swage fitting with any other type lay, construction or grade of wire rope, it is recommended that the termination be destructive tested and documented to prove the adequacy of the assembly to be manufactured.
- Resists cracking when swaged (equals or exceeds stainless steel sleeves).
- Stamp for identification after swaging without concern for fractures (as per directions in the Wire Rope End Termination User's Manual).

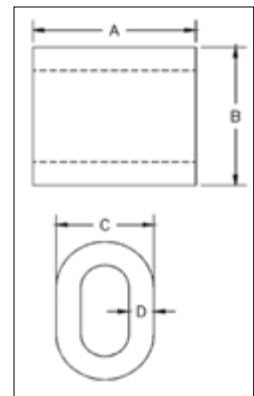

S-506 COLD TUFF® Duplex Non-Tapered Sleeves

S-506 Steel Duplex Non-Tapered Sleeve Specifications										Swager / Die Data	
S-506 Stock No.	Rope Size		Weight Per 100 (lb)	Pkg. Qty.	Before Swage Dimensions (in)				Max. After Swage Dimensions (in)	Die Description	Stock No. 500 Tons 1000 Tons 1500 Tons 5 x 7
	(in)	(mm)			A	B	C	D			
1039334	5/16	8	17	200	1.25	1.06	.81	.19	.77	3/8 1st Stage	1192364
1039352	3/8	9-10	13	100	1.25	1.12	.81	.14	.77	3/8 1st Stage	1192364
1039370	7/16	11	31	50	1.63	1.41	1.02	.19	1.03	1/2 1st Stage	1192408
1039398	1/2	13	27	50	1.63	1.44	1.02	.16	1.03	1/2 1st Stage	1192408
1039414	9/16	14	63	25	2.25	1.72	1.23	.23	1.29	5/8 1st Stage	1192444
1039432	5/8	16	54	25	2.25	1.84	1.28	.20	1.29	5/8 1st Stage	1192444
1039450	3/4	18-20	91	10	2.63	2.16	1.52	.23	1.55	3/4 1st Stage	1192462
1039478	7/8	22	126	10	2.88	2.50	1.75	.27	1.80	7/8 1st Stage	1192480
1039496	1	25-26	187	10	3.06	2.84	2.00	.33	2.05	1 1st Stage	1192505
1039539	1-1/4	30-32	384	Bulk	4.06	3.50	2.50	.38	2.56	1-3/8 Socket	1193023

Note: Fittings designed only to be used on exact sizes listed.

G-411



- Hot-dip galvanized steel.
- The standard choice for light duty loading conditions and applications.
- Meets the performance requirements of Federal Specification FF-T-276b Type II, except for those provisions required of the contractor.

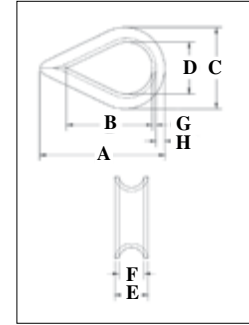

Standard Wire Rope Thimbles

Rope Diameter		Stock No	Weight Per 100 (lb)	Dimensions (in)							
(in)	(mm)			A	B	C	D	E	F	G	H
1/8	3-4	1037256	3.50	1.94	1.31	1.06	.69	.25	.16	.05	.13
3/16	5	1037274	3.50	1.94	1.31	1.06	.69	.31	.22	.05	.13
1/4	6-7	1037292	3.50	1.94	1.31	1.06	.69	.38	.28	.05	.13
5/16	8	1037318	4.00	2.13	1.50	1.25	.81	.44	.34	.05	.13
3/8	9-10	1037336	6.70	2.38	1.63	1.47	.94	.53	.41	.06	.16
1/2	11-13	1037354	12.50	2.75	1.88	1.75	1.13	.69	.53	.08	.19
5/8	16	1037372	34.50	3.50	2.25	2.38	1.38	.91	.66	.13	.34
3/4	18-20	1037390	47.10	3.75	2.50	2.69	1.63	1.08	.78	.14	.34
7/8	22	1037416	84.60	5.00	3.50	3.19	1.88	1.27	.94	.16	.44
1	24-26	1037434	97.50	5.69	4.25	3.75	2.50	1.39	1.06	.16	.41
1-1/8 - 1-1/4	28-32	1037452	175.00	6.25	4.50	4.31	2.75	1.75	1.31	.22	.50

7

G-408



- Hot-dip galvanized steel.
- Recommended for light duty applications where assembly into another fitting (i.e., shackle or master link) is required.

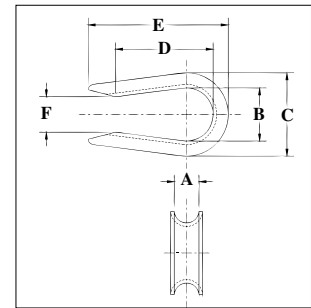

Open Pattern Thimbles

Rope Diameter		Stock No	Weight Per 100 (lb)	Dimensions (in)					
(in)	(mm)			A	B	C	D	E	F
1/4	6-7	1037531	3.00	.28	.69	1.06	1.41	2.03	.38
5/16	8	1037559	3.80	.34	.81	1.25	1.53	2.16	.50
3/8	9-10	1037577	7.00	.44	.94	1.47	1.72	2.47	.62
1/2	11-13	1037595	12.50	.53	1.12	1.75	1.97	2.84	.75
5/8	16	1037611	25.00	.66	1.38	2.38	2.34	3.59	1.00

S-412



- Cast ductile iron.
- Fits pin for open wire rope socket, boom pendant clevis, and wedge socket.

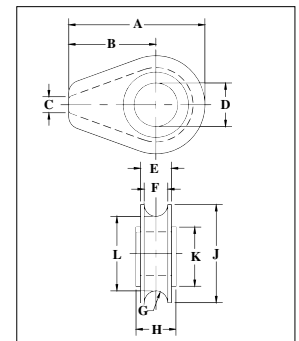

Solid Wire Rope Thimbles

Rope Diameter		Stock No	Weight Per 100 (lb)	Dimensions (in)										
(in)	(mm)			A	B	C	D	E	F	G	H	J	K	L
1/2	13	1037121	.61	2.81	1.75	.25	1.06	.75	.56	.28	.88	2.13	1.63	1.56
5/8	16	1037149	2.21	4.69	3.00	.38	1.31	1.06	.81	.41	1.13	3.38	2.25	2.56
3/4	18-20	1037167	2.32	4.69	3.00	.38	1.50	1.06	.81	.41	1.38	3.38	2.25	2.56
7/8	22	1037185	5.45	6.06	3.81	.50	1.75	1.38	1.06	.53	1.63	4.50	3.25	3.44
1	24-26	1037201	5.25	6.06	3.81	.50	2.13	1.38	1.06	.53	1.81	4.50	3.25	3.44
1-1/8	28-30	1037229	9.29	7.25	4.56	.63	2.38	1.75	1.31	.66	2.06	5.38	3.88	4.06
1-1/4 - 1-3/8	32-35	1037247	9.81	7.25	4.56	.63	2.63	1.94	1.53	.78	2.31	5.38	3.88	4.13

G-414



- Available in hot-dip galvanized or stainless steel (Type 304).
- Stainless steel recommended for more corrosive environments where greater protection is required.
- Greater protection against wear and deformation of the wire rope eye.
- Longer service life.
- Meets the performance requirements of Federal Specification FF-T-276b Type III, except for those provisions required of the contractor.

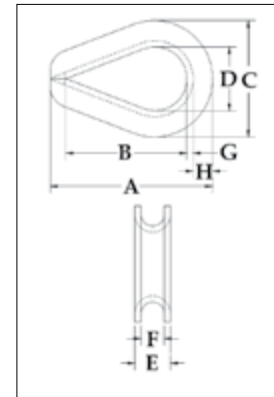

Extra Heavy Wire Rope Thimbles

Rope Diameter		Stock No.		Weight Per 100 (lb)	Dimensions (in)							
(in)	(mm)	G-414 Stock No	SS-414 Stainless		A	B	C	D	E	F	G	H
1/4	6-7	1037639	1037960	7	2.19	1.62	1.50	.88	.41	.28	.06	.25
5/16	8	1037657	1037988	14	2.50	1.88	1.81	1.06	.50	.34	.08	.30
3/8	9-10	1037675	1038004	23	2.88	2.12	2.12	1.12	.63	.41	.11	.39
7/16	11-12	1037693	-	37	3.25	2.38	2.38	1.25	.72	.47	.12	.45
1/2 - 9/16	13-15	1037719	1038022	50	3.62	2.75	2.75	1.50	.89	.59	.15	.48
5/8	16	1037755	1038040	82	4.25	3.25	3.12	1.75	1.00	.66	.16	.53
3/4	18-20	1037773	1038068	157	5.00	3.75	3.81	2.00	1.22	.78	.22	.69
7/8	22	1037791	-	190	5.50	4.25	4.25	2.25	1.38	.94	.22	.78
1	24-26	1037817	-	280	6.12	4.50	4.75	2.50	1.56	1.06	.25	.88
1-1/8 - 1-1/4	28-32	1037835	-	-	7.00	5.12	5.88	2.88	1.88	1.31	.25	1.25
1-1/4 - 1-3/8	32-35	1037853	-	830	9.08	6.50	6.81	3.50	2.25	1.44	.37	1.29
1-3/8 - 1-1/2	35-38	1037871	-	1250	9.00	6.25	7.12	3.50	2.62	1.56	.50	1.31
1-5/8	40	1037899	-	-	11.25	8.00	8.12	4.00	3.00	1.72	.50	1.38
1-3/4	44	1037915	-	1860	12.19	9.00	8.50	4.50	3.06	1.84	.50	1.50
1-7/8 - 2	48-52	1037933	-	2780	15.12	12.00	10.38	6.00	3.38	2.09	.50	1.69
2-1/4	56	1037951	-	-	17.50	14.00	11.88	7.00	3.88	2.38	.62	1.82

G-414 SL



- Prevents the shackle from being removed and replaced in the field, which could compromise the certified integrity of the sling assembly.
- Available in hot-dip galvanized. Crosby's shackle locking thimbles are galvanized after the welding of the wedge has been completed.
- Greater protection against wear and deformation of the wire rope eye.
- Longer service life.
- Meets the performance requirements of Federal Specification FF-T-276b Type III, except for those provisions required of the contractor.

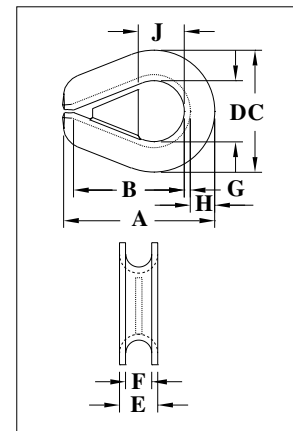

Extra Heavy Wire Rope Thimbles (Shackle-Loc)

Rope Diameter		Stock No	Weight Per 100 (lb)	Dimensions (in)								
(in)	(mm)			A	B	C	D	E	F	G	H	J
3/8	9-10	1036800	24	2.88	2.12	2.12	1.12	.63	.41	.11	.39	.81
1/2 - 9/16	13-15	1036808	55	3.62	2.75	2.75	1.50	.89	.59	.15	.48	1.12
5/8	16	1036817	82	4.25	3.25	3.12	1.75	1.00	.66	.16	.53	1.25
3/4	18-20	1036826	161	5.00	3.75	3.81	2.00	1.22	.78	.22	.69	1.50
7/8	22	1036835	206	5.50	4.25	4.25	2.25	1.38	.94	.22	.78	1.63
1	24-26	1036844	300	6.12	4.50	4.75	2.50	1.56	1.06	.25	.88	1.88
1-1/8 - 1-1/4	28-32	1036853	425	7.00	5.12	5.88	2.88	1.88	1.31	.25	1.25	2.13
1-3/8 - 1-1/2	35-38	1036862	1317	9.00	6.25	7.12	3.50	2.62	1.56	.50	1.31	2.50